



WTF

CYLINDRICAL PROTECTIVE HOUSING FOR USE IN SEVERE ENVIRONMENTAL CONDITIONS

- *Ideal for external use*
- *Resistant to pressurised water jets*
- *Resistant to highly humid environments*
- *Resistant to saline environments / food industry*

INTRODUCTION

- WTF is a **cylindrical protective housing for safety light curtain** designed to secure operators working on dangerous machines in an industrial environment including the protection of access to the stations in severe environmental conditions.
- WTF is particularly suitable for applications in the food industry using inert materials.
- Thanks to its features, WTF is also the ideal solution for all uses in external environments (rain, sun, environments that generate condensation).
- The cylindrical housing WTF can fit the following safety light curtain REER families: EOS2/EOS4.

PRODUCT STRUCTURE

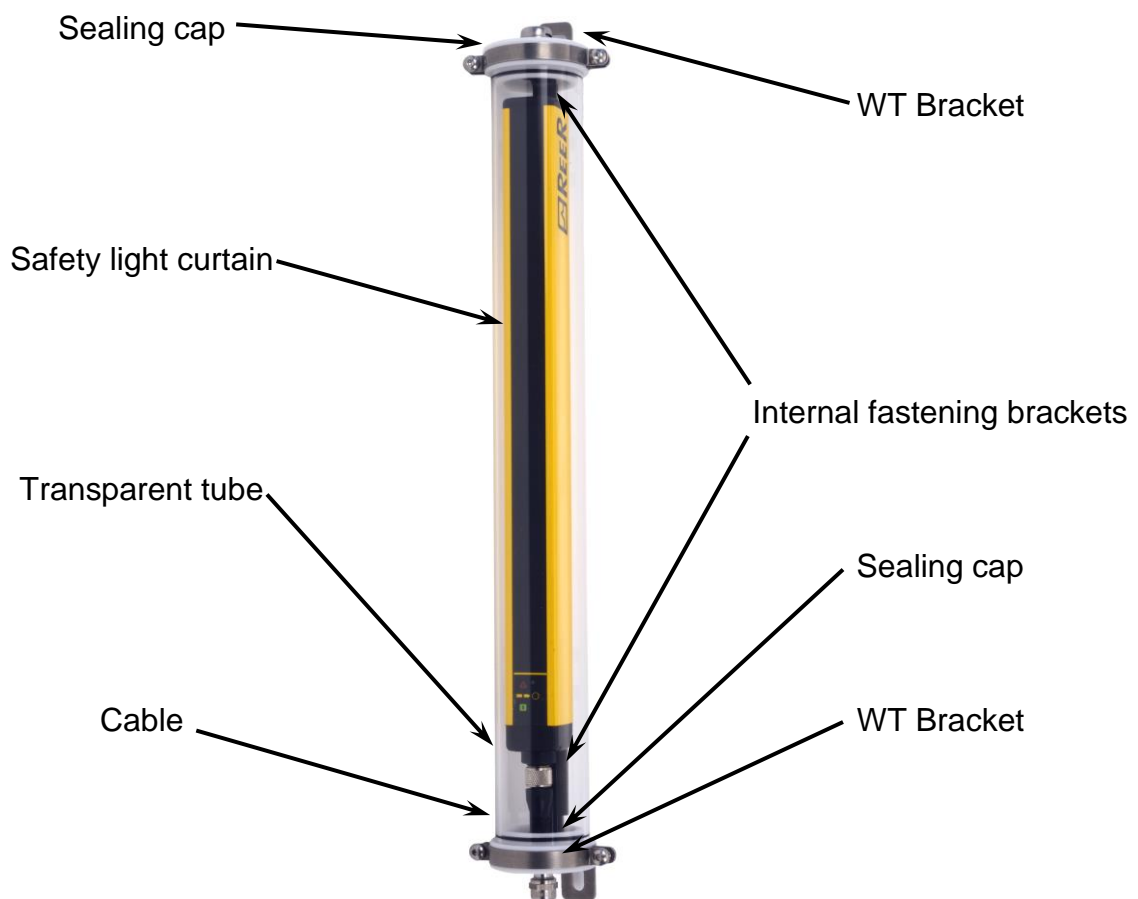

Figure 1

GENERAL CHARACTERISTICS

- Resistant to pressurised water streams of up to 100 bar.
- Integrated anti-condensation system through the GORE™ vent.
- Degree of protection IP69K.
- Operating temperature from -10° to 55°C.
- CE certified.

PROTECTIVE HOUSING TECHNICAL CHARACTERISTICS

Fastenings	Via 2 WT circular brackets		
Operating temperature	°C	-10 ÷ 55	
Operating temperature with pressurised water	°C	10 ÷ 55 (max. water pressure = 100 bar)	
Material	Transparent tube	PMMA (Polymethylmethacrylate) Ø 50mm	
	Sealing caps	POM C Ø 56mm / Silicone O-RING	
	WT EOS brackets	Stainless steel (AISI 316L)	
Degree of protection	IP69K		

LIGHT CURTAIN ELECTRICAL CONNECTIONS

EMITTER			
PIN	COLOR	NAME	DESCRIPTION
1	Brown	24VDC	+24VDC power supply
3	Blue	0VDC	0VDC power supply
5	Grey	PE	Ground connection
2	White	RANGE0 *	Barrier configuration
4	Black	RANGE1 *	

RECEIVER			
PIN	COLOR	NAME	DESCRIPTION
2	Brown	24VDC	+24VDC power supply
7	Blue	0VDC	0VDC power supply
8	Red	PE	Ground connection
1	White	OSSD1	Safety static outputs
3	Green	OSSD2	
5	Grey	SEL_A	Barrier configuration
6	Pink	SEL_B	
4	Yellow	K1_K2	External contactors Feedback

DIMENSIONS (mm)

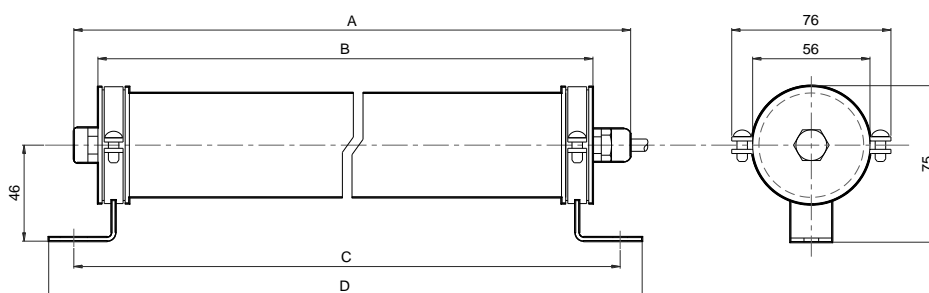

Cable length TX (m): 50,15,10(standard),6
Cable length RX (m): 30,15,10(standard),6
Ø max (mm) = 5,8

Figure 2

MODEL	150	300	450	600	750	900	1050	1200	1350	1500	1650	1800	2B	3B	4B
Dimension "A"	320	470	620	770	920	1070	1220	1370	1520	1670	1820	1970	760	1060	1160
Dimension "B"	290	440	590	740	890	1040	1190	1340	1490	1640	1790	1940	730	1030	1130
Dimension "C" (± 3mm)	315	465	615	765	915	1065	1215	1365	1515	1665	1815	1965	755	1055	1155
Dimension "D"	337	487	637	787	937	1087	1237	1387	1537	1687	1837	1987	777	1077	1177

WT EOS FASTENING BRACKET

- The figure illustrates the assembly of the brackets for the top and bottom caps of the housing.

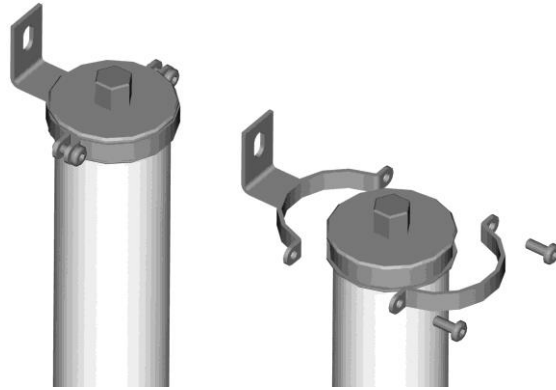



Figure 3

DISTANCE FROM REFLECTIVE SURFACES

 The presence of reflective surfaces close to the light curtain may cause occasional reflections that prevent sensing. Referring to Figure 4, object **A** is not detected due to surface **S** that, reflecting the beam, closes the optical path between the Emitter and Receiver. Therefore, a minimum distance d must be maintained between any reflecting surfaces and the guarded area. The minimum distance d must be calculated according to the distance l between the Emitter and Receiver and taking into account that the angle of projection and reception is 6° (due to the Polycarbonate cylinder optical interference).

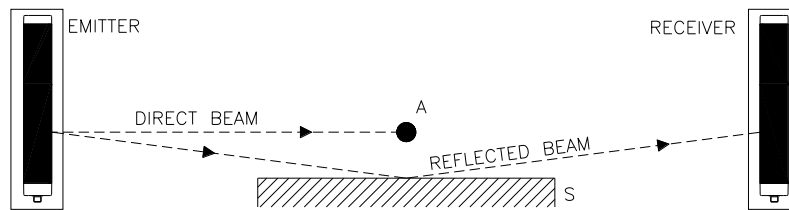

Figure 4 - Reflective surfaces

The distance d to be kept as the distance l between Emitter and Receiver varies is shown in Figure 5.

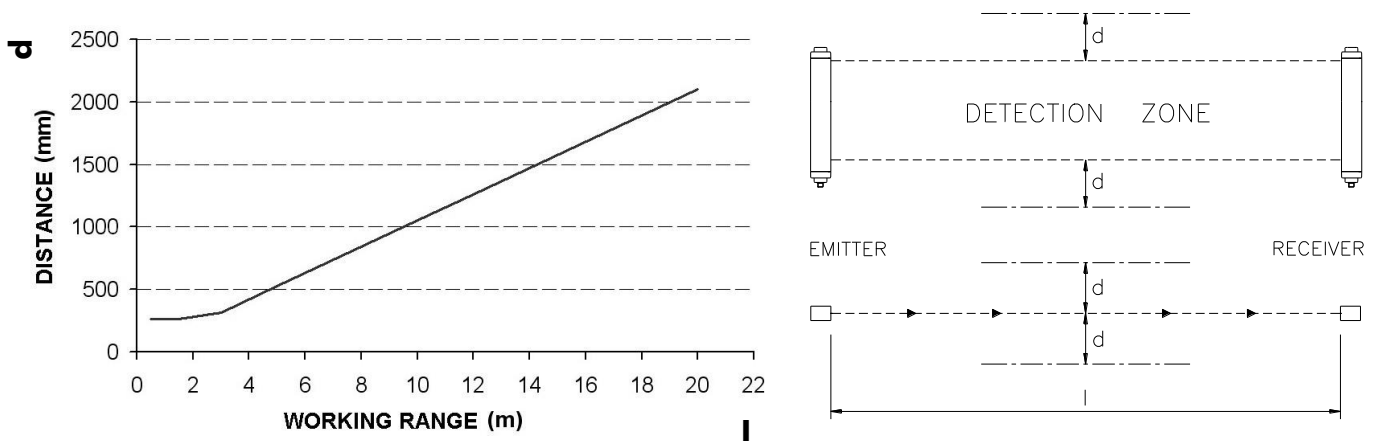

Figure 5 - Minimum distance d

After installing the system, check for any reflective surface that intercept the beams, first of all at the centre and then close to the Emitter and Receiver. During this procedure, the red led on the Receiver must never switch off.